



## WATER-COOLED CABLE ORDER FORM

MCM SIZE	TYPE	TERMINAL 1	TERMINAL 2	LENGTH IN INCHES	OPTIONS
<input style="width: 30px; height: 30px; border: 1px solid black;" type="text"/> <input style="width: 30px; height: 30px; border: 1px solid black;" type="text"/>	<input style="width: 30px; height: 30px; border: 1px solid black;" type="text"/> <input style="width: 30px; height: 30px; border: 1px solid black;" type="text"/>	<input style="width: 30px; height: 30px; border: 1px solid black;" type="text"/> <input style="width: 30px; height: 30px; border: 1px solid black;" type="text"/> <input style="width: 30px; height: 30px; border: 1px solid black;" type="text"/> <input style="width: 30px; height: 30px; border: 1px solid black;" type="text"/>	<input style="width: 30px; height: 30px; border: 1px solid black;" type="text"/> <input style="width: 30px; height: 30px; border: 1px solid black;" type="text"/> <input style="width: 30px; height: 30px; border: 1px solid black;" type="text"/> <input style="width: 30px; height: 30px; border: 1px solid black;" type="text"/>	<input style="width: 30px; height: 30px; border: 1px solid black;" type="text"/> <input style="width: 30px; height: 30px; border: 1px solid black;" type="text"/> <input style="width: 30px; height: 30px; border: 1px solid black;" type="text"/>	<input style="width: 30px; height: 30px; border: 1px solid black;" type="text"/> <input style="width: 30px; height: 30px; border: 1px solid black;" type="text"/>
<div style="display: flex; justify-content: space-between;"> <div style="width: 20%;"> <p><b>MCM SIZE</b></p> <p>35 = 350MCM 40 = 400MCM 50 = 500MCM 60 = 600MCM 75 = 750MCM 10 = 1000MCM</p> </div> <div style="width: 20%;"> <p><b>CABLE TYPE</b></p> <p>WS = COLOR-FLEX AP = AMERICAN POWER UR = EURO-FLEX CR = COMPLEX</p> </div> <div style="width: 20%;"> <p><b>TERMINAL 1</b></p> <p>See terminal chart.</p> </div> <div style="width: 20%;"> <p><b>TERMINAL 2</b></p> <p>See terminal chart.</p> </div> <div style="width: 20%;"> <p><b>LENGTH IN INCHES</b></p> <p>PLEASE SPECIFY</p> </div> <div style="width: 20%;"> <p><b>OPTIONS</b></p> <p>S = SILVER PLATING E = EXO SYSTEM ON CABLE B = FLEX-CEL CONSTRUCTION SB = STAINLESS STEEL BANDS DB = DOUBLE BANDING</p> </div> </div>					

**EXAMPLE:**            **35WSW1FW6-22-E**  
**DESCRIPTION:**    **22 in. 350MCM COLOR-FLEX WITH W1F & W6 TERMINALS,**  
                                 **CABLE WRAPPED WITH EXO.**

## TERMINAL CHART

### MOST COMMONLY USED WATER-COOLED CABLE TERMINALS

#### W1

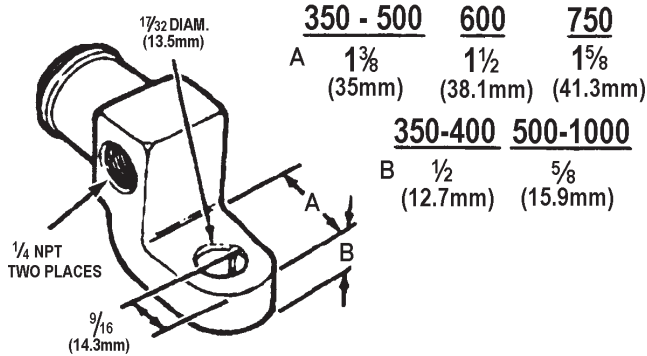

#### W1F & W1F-2

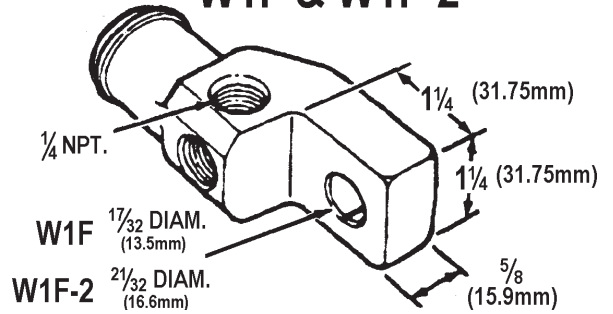

#### W2

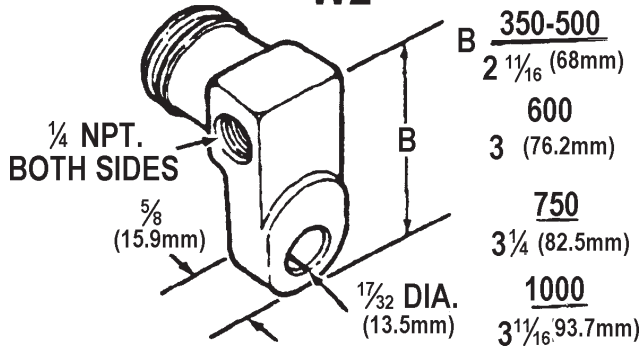

#### W4

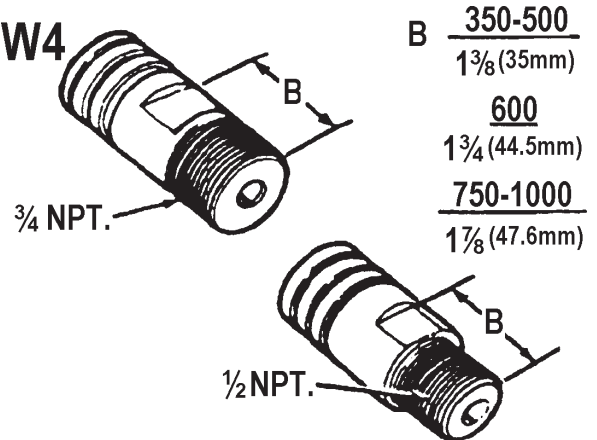

#### W5

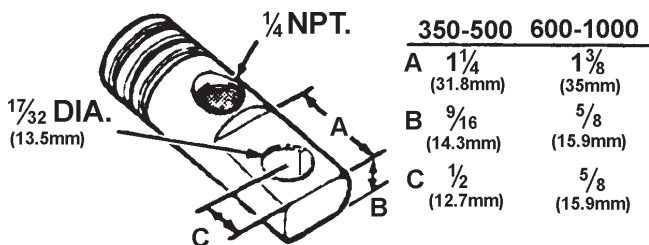

#### W6

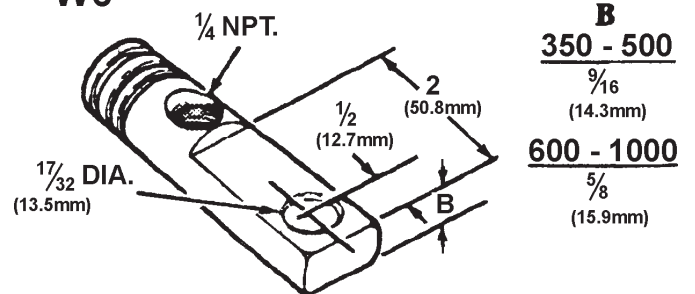

#### W6-2

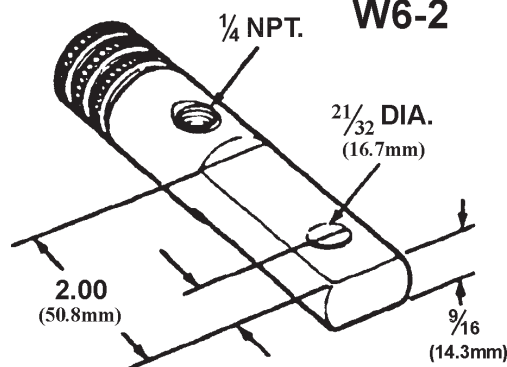

### TERMINAL CHART

MOST COMMONLY USED WATER-COOLED CABLE TERMINALS

